

# High Precision Chip Resistors

- Thin film passivated NiCr resistor
- Very tight tolerance from  $\pm 0.01\% \sim 1\%$
- Extremely low TCR from  $\pm 5 \sim \pm 50 \text{PPM}/^\circ\text{C}$
- Wide R-value range  $1\Omega \sim 3\text{M}\Omega$

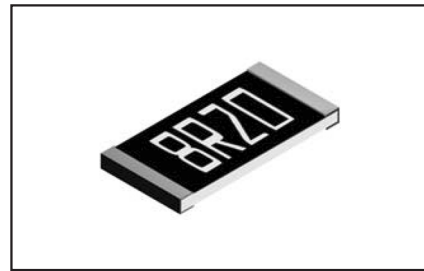

## GENERAL SPECIFICATIONS

Model	Power Rating at 70°C	Max Operating Voltage	Max Overloading Voltage	Resistance Tolerance(%)	Resistance Range	TCR (ppm/°C)
AR02 (0402)	1/16W	25V	50V	[±0.10] [±0.25] [±0.50]	10KΩ~205KΩ	±25 ±50
AR03 (0603)	1/16W	50V	100V	[±0.05] [±0.10] [±0.25] [±0.50]	4.7Ω~105KΩ 4.7Ω~1MΩ 2Ω~1MΩ	±25 ±50
AR05 (0805)	1/10W	100V	200V	[±0.05] [±0.10] [±0.25] [±0.50]	4.7Ω~1MΩ 4.7Ω~2.5MΩ 1Ω~2.5MΩ	±25 ±50
AR06 (1206)	1/8W	150V	300V	[±0.05] [±0.10] [±0.25] [±D 0.5]	4.7Ω~1MΩ 4.7Ω~2.5MΩ 1Ω~2MΩ	±25 ±50
AR10 (2010)	1/4W	150V	300V	[±0.05] [±0.10]	4.7Ω~1MΩ 4.7Ω~3MΩ	±25
AR12 (2512)	1/2W			[±0.25] [±0.50]	1Ω~3MΩ	±50

## CHARACTERISTICS

TEST	Specification		Method
	Tol. ≤ 0.05%	Tol. > 0.05%	
TCR	As Spec		MIL-STD-202F Method 304 +25/-55/+25/+125/+25°C
Operating Temp. Range			-55°C~+155°C
Short Time Overload	$\Delta R \pm 0.05\%$	$\Delta R \pm 0.5\%$	JIS-C-5202-5.5 RCWV×2.5 or maximum Overloading Voltage, 5secs.
Dielectric Withstand Voltage	By Type		MIL-STD-202F Method 301 Apply maximum Overloading Voltage for 1minute
Insulation Resistance	> 1000MΩ		MIL-STD-202F Method 302 Apply 100VDC for 1minute
Thermal Shock	$\Delta R \pm 0.05\%$	$\Delta R \pm 0.25\%$	MIL-STD-202F Method 107G -55°C~+150°C, 100Cycles
Load Life	$\Delta R \pm 0.05\%$	$\Delta R \pm 0.2\%$	MIL-STD-202F Method 108A RCWV, 70°C, 1.5 hours on, 0.5 hours off Total 1000~1048 hours
Humidity (Steady State)	$\Delta R \pm 0.05\%$	$\Delta R \pm 0.3\%$	MIL-STD-202F Method 103B 40°C, 90~95%RH, RCWV 1.5hours on Total 1000~1048 hours
Resistance to Dry Heat	$\Delta R \pm 0.05\%$	$\Delta R \pm 0.2\%$	JIS-C-5202-7.2 96 hours, +155°C without load
Low Temp. Operation	$\Delta R \pm 0.05\%$	$\Delta R \pm 0.2\%$	JIS-C-5202-7.1 1 hours, -65°C, followed by 45 minute of RCWV
Bending Strength	$\Delta R \pm 0.05\%$	$\Delta R \pm 0.2\%$	JIS-C-5202-6.1.4 Bending Amplitude 3mm for 10secs
Solderability	95% Minimum coverage		MIL-STD-202F Method 208H 235°C±5°C, 2±5(secs)
Resistance to Soldering Heat	$\Delta R \pm 0.05\%$	$\Delta R \pm 0.2\%$	MIL-STD-202F Method 210E 260±5°C, 10±1 secs

\* Storage Temperature: 25±3°C, Humidity < 80% RH

## DIMENSIONS [mm]

Model	Dimensions [mm]				
	L	W	T	D1	D2
Ar02	0.100±0.05	0.50±0.05	0.30±0.05	0.20±0.10	0.20±0.10
AR03	1.55±0.10	0.80±0.10	0.45±0.10	0.30±0.20	0.30±0.20
AR05	2.00±0.15	1.25±0.15	0.55±0.10	0.30±0.20	0.45±0.25
AR06	3.05±0.15	1.55±0.15	0.55±0.10	0.42±0.20	0.35±0.25
AR10	4.90±0.15	2.40±0.15	0.55±0.10	0.60±0.30	0.50±0.25
AR12	6.30±0.15	3.10±0.15	0.55±0.10	0.60±0.30	0.50±0.25

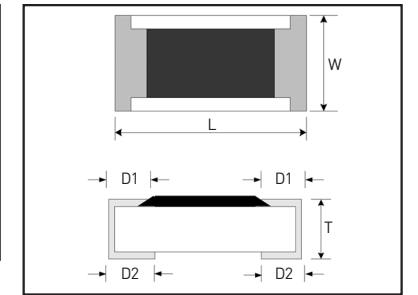

## SPECIAL SPECIFICATIONS

Model	Power Rating At 70°C	Operating Temp. Range	Max Operating Voltage	Max Overloading Voltage	Resistance Tolerance(%)	Resistance Range	TCR (ppm/°C)
AR02 (0402)	1/16W	-55°C ~ +155°C	25V	50V	[±0.01] [±0.05] [±0.10]	49.9Ω~3KΩ 49.9Ω~12KΩ	±5 ±10 ±15
AR03 (0603)	1/16W	-55°C ~ +155°C	50V	100V	[±0.01] [±0.05] [±0.10]	25Ω~15KΩ 25Ω~100KΩ 4.7Ω~332KΩ	±5 ±10 ±15
AR05 (0805)	1/10W	-55°C ~ +155°C	100V	200V	[±0.01] [±0.05] [±0.10]	25Ω~30KΩ 25Ω~200KΩ 4.7Ω~500KΩ	±5 ±10 ±15
AR06 (1206)	1/8W	-55°C ~ +155°C	150V	300V	[±0.01] [±0.05] [±0.10]	25Ω~50KΩ 25Ω~500KΩ 4.7Ω~1MΩ	±5 ±10 ±15
AR10 (2010)	1/4W	-55°C ~ +155°C	150V	300V	[±0.01] [±0.05] [±0.10]	25Ω~100KΩ 25Ω~500KΩ 4.7Ω~1MΩ	±5 ±10 ±15
AR12 (2512)	1/2W	-55°C ~ +155°C	150V	300V	[±0.01] [±0.05] [±0.10]	25Ω~100KΩ 25Ω~500KΩ 4.7Ω~1MΩ	±5 ±10 ±15

## DERATING CURVE

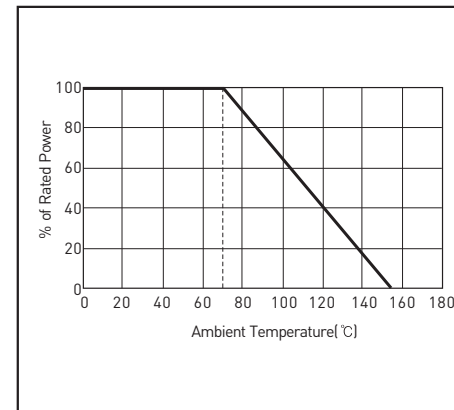

## ORDERING PROCEDURE EXAMPLE

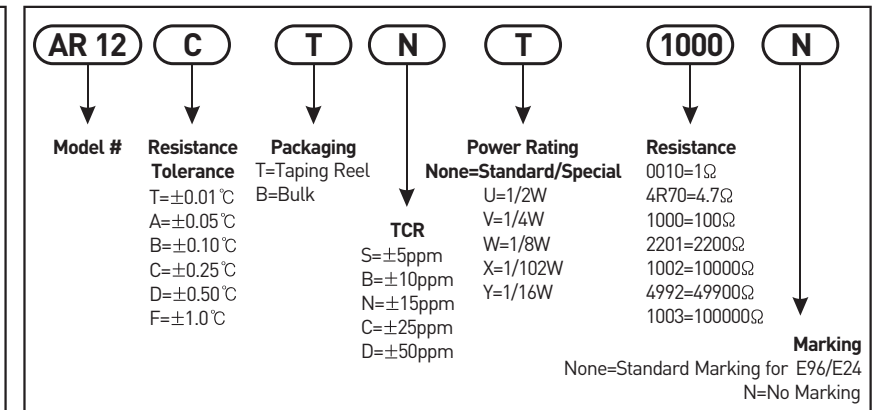

## RECOMMEND LAND PATTERN

Model	Dimension [mm]		
	A	B	C
AR12	4.90	1.60	3.10±0.2
AR10	3.60	1.40	2.50±0.2
AR06	2.00	1.15	1.70±0.2
AR05	1.00	1.00	1.35±0.2
AR03	0.80	1.00	0.90±0.2
AR02	0.50	0.50	0.60±0.2

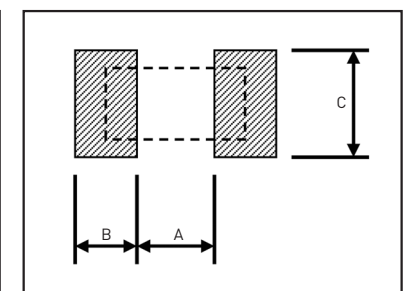

# Leaded Metal Film Precision Resistors

**Features**

- Low Noise
- Low TCR  $\pm 15 \sim 100 \text{ppm}/^\circ\text{C}$
- High Precision from  $\pm 0.1\% \sim 1\%$
- Usually broad selection of power rating 1/8w, 1/4w, 1/2w, 1w, 2w, 3w, at 70 °C
- Lead(Pb)free and RoHS compliant

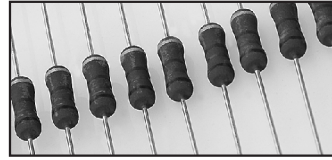

**GENERAL SPECIFICATIONS (HIGH POWER)**

Type	Power Rating At 70 °C	Operating Temp. Range	Max Working Voltage	Max Overload Voltage	Dielectric Withstanding Voltage	Resistance Range $\leq 0.25\% \text{ E192}$	Resistance Range $\leq 0.50\% \text{ E96}$	TCR( $\pm \text{ppm}/^\circ\text{C}$ )
0318 (0318H)	1/8W (1/4W)	-55 °C ~155 °C	200V (200V)	400V (400V)	300V (400V)	100Ω ~100KΩ	10Ω ~1MΩ	±15
0623 (0623H)	1/4W (1/2W)		250V (300V)	500V (600V)	500V (500V)			
0932 (0932H)	1/2W (1W)		350V (400V)	700V (800V)	500V (700V)			
1145 (1145H)	1W (2W)		450V (500V)	1000V (1000V)	1000V (1000V)			
1550 (1550H)	2W (3W)		500V (500V)	1000V (1000V)	1000V (1000V)			

**CHARACTERISTICS**

Short Time Overload	$\pm [0.25\% + 0.05\Omega]$	JIS-C 5202-5.5 RCW*2.5 or maximum Overloading Voltage, 5secs.
Temperature Coefficient	By Type	Resistance value at room temperature and room Temperature +100 °C
Dielectric Withstanding Voltage	By Type	MIL-STD-202F Method 301 Apply maximum Overload Voltage for 1minute
Pulse Overload	$\pm [0.75\% + 0.05\Omega]$	JIS-C5205 5.8 4 times RCW for 10000cycles (1sec. on, 25secs. off)
Insulation Resistance	> 1000MΩ	MIL-STD-202F Method 302 Apply 100VDC for 1 minute
Load Life	$\pm [1.5\% + 0.05\Omega]$	MIL-STD-202F Method 108A RCW, 70 °C, 1.5hours on, 0.5hours off, total 1000~1048hours
Humidity(Steady State)	$\pm [1.5\% + 0.05\Omega]$	MIL-STD-202F Method 103B 40 °C, 90~95%RH, RCW 1.5hours on, 0.5hours off Total 1000~1048hours
Solderability	95% Minimum Coverage	MIL-STD 202F Method 208H 245 °C $\pm 5^\circ\text{C}$ , 5 $\pm 0.5$ (secs.)
Resistance To Solvent	No deterioration of Coatings and markings	JIS-C5202 6.9 Trichothane for 1minute with ultrasonic
Terminal Strength	Tensile : $\geq 2.5\text{Kg}$	Direct Load for 10secs. In the direction off the terminal leads.
Shelf Life	$\Delta R = \pm 0.1\%$	12months at room temperature 25 $\pm 3^\circ\text{C}$ , 80%RH maximum

**DIMENSIONS [mm]**

Type	L	D	H	D
0318	3.3+0.7/-0.2	1.8±0.3	29±2.0	0.45±0.03
0623	6.3±0.5	2.3±0.3	28±2.0	0.55±0.03
0932	9.0±0.5	3.2±0.5	26±2.0	0.65±0.03
1145	11.5±1.0	4.5±0.5	35±2.0	0.78±0.03
1550	15.5±1.0	5.0±0.5	32±2.0	0.78±0.03

**DERATING CURVE**

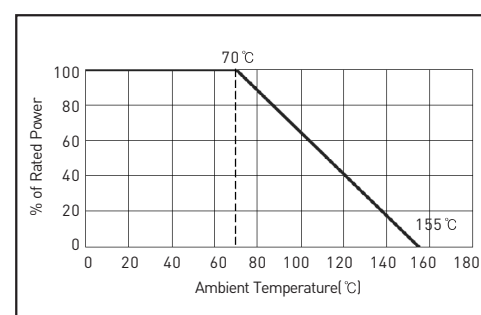

**ORDERING PROCEDURE EXAMPLE**

<b>MFR</b>	<b>0623</b>	<b>B</b>	<b>T</b>	<b>C</b>	<b>V</b>	<b>1001</b>	<b>MA</b>
<b>Model #</b>	<b>Dimensions</b>	<b>Tolerance</b>	<b>Packing</b>	<b>TCR</b>	<b>Power Rating</b>	<b>Resistance</b>	<b>Special</b>
0623: 6.30X2.30mm	B: $\pm 0.1\%$	A: Ammo	N: $\pm 15 \text{ppm}/^\circ\text{C}$	R: 3W	None: Standard	R100: 0.1Ω	None: Standard
0932: 9.00X3.20mm	C: $\pm 0.25\%$	B: Bulk	C: $\pm 25 \text{ppm}/^\circ\text{C}$	S: 2W	MA: MA-type	0100: 10.0Ω	MA: MA-type
1145: 11.5X4.50mm	D: $\pm 0.5\%$	T: Taping Reel	D: $\pm 50 \text{ppm}/^\circ\text{C}$	T: 1W	MB: MB-type	2201: 2200Ω	MB: MB-type
1550: 15.5X5.00mm	F: $\pm 1\%$		E: $\pm 100 \text{ppm}/^\circ\text{C}$	U: 1/2W	MC: MC-type	1002: 10000Ω	MC: MC-type
				V: 1/4W	FA: FA-type	4992: 49900Ω	FA: FA-type
				W: 1/8W	FB: FB-type	1003: 100000Ω	FB: FB-type
					FC: FC-type	1004: 1000000Ω	FC: FC-type
					PA: PA-type		PA: PA-type
					PB: PB-type		PB: PB-type
					PC: PC-type		PC: PC-type

**TAPING/PACKING SPECIFICATIONS**

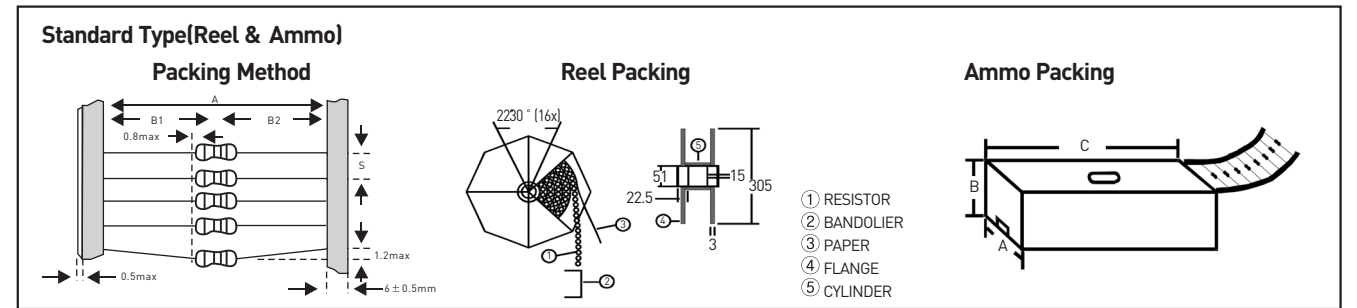

Packing Codes	Packing Methods			Reel Packing		Ammo Packing			Qty
	A	B1-B2	S	Across Flange(A)	Qty	A	B	C	
0318	52+1/-0	1.2	5	72	5,000	-	-	-	-
0623	52+1/-0	1.2	5	72	5,000	-	-	-	-
0932	52+1/-0	1.2	5	72	2,500	-	-	-	-
1145	52+1/-0	1.5	5	95	2,000	-	-	-	-
1550	52+1/-0	1.5	10	95	1,000	-	-	-	-
0318	26+1/-0	1.0	5	-	-	80	75	264	5,000
0623	26+1/-0	1.0	5	-	-	80	105	264	5,000
0932	52+1/-0	1.2	5	-	-	80	46	264	1,000
1145	73+1/-0	1.5	5	-	-	103	82	265	1,000
1550	73+1/-0	1.5	10	-	-	103	96	265	1,000

**Special Type (Bulk)**

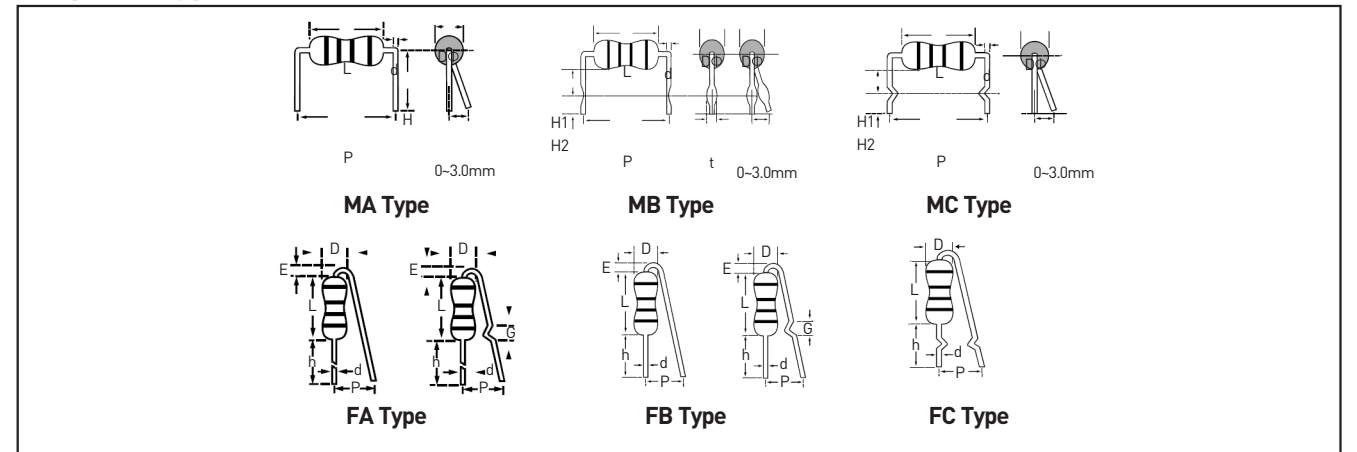

\*Please ask RARA for more information.

**Special Type (Reel & Ammo)**

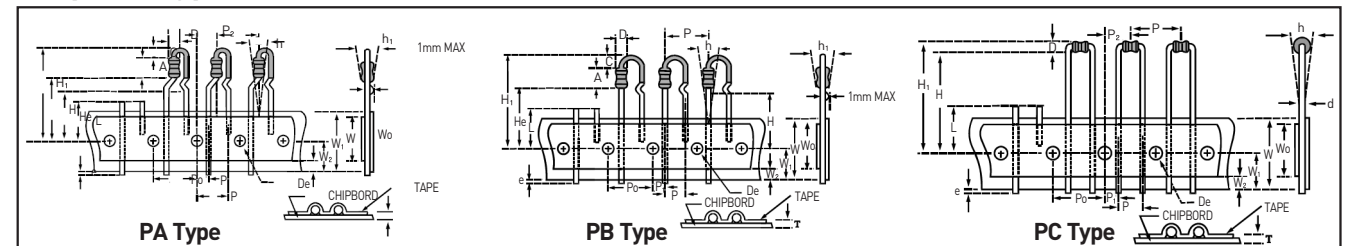

Dimension	AMMO			REEL				
	A	B	C	A	B	C	W1	W2
Unit:mm	53	120	325	31	76	312	44	50
Qty:EA	2000/3000			2500/3000				

\*Please ask RARA for more information.

# 1/4 Watt Precision Thin Film Resistors

High precision, thin film resistors. A standard TCR of 2ppm/°C is achieved with a Ni-Cr-Si alloy spattered onto an alumina substrate. Operating temperatures from -55°C to +125°C. These models also exhibit excellent long-term stability, low current noise, a low voltage coefficient and a low thermal EMF. Typical applications are: Discrete voltage dividers, analogue circuits in industrial measuring equipment, control, medical electronics, ATE, aerospace, and reliable power electronics.

## GENERAL SPECIFICATIONS

Model	Resistance Range[Ω]	1)TCR [±ppm/°C]	1)Tolerance [%]	Standard Resistance	2)Power Rating[W]	Working Voltage[V]
TP48 TP47 TP46 TP45	100~20K	±1[X]	T [0.01]	E96 and E24(include 2.5 and 5.0) * any resistance value	0.25	$\sqrt{P.R}$
	100~150K	±2[Y]	Q [0.02]			
		±5[Z]	A [0.05]			
TP48, TP47	50~150K	±10[N]	B [0.1]			
TP46, TP45	50~510K					
TP48, TP47	10~150K	±25[E]	B [0.1]			
TP46, TP45	10~820K					

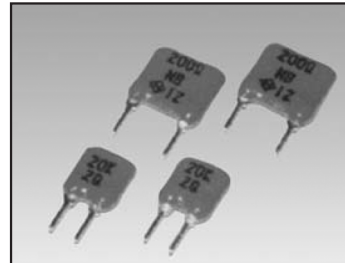

1) Conditions: -55 to +125°C    2) Conditions: -55°C to +70°C  
\* 4 or more significant digits and odd resistances, please call factory about printing method

## CHARACTERISTICS

Values in [ ] mean change in Ω after test

Operating Temperature Range	-55°C to +125°C
Storage Temperature Range	-55°C to +125°C
Dielectric Withstanding Voltage	[±0.03%]
Short Time Over Load	Rating power X 2.5, 5 sec.
Moisture Resistance	[±0.05%] 1000 hours.
Vibration	[Not Specified]
Shelf Life Stability	[±0.03%] One year at 25°C
Voltage Coefficient	[<0.1ppm/V] THD at rating power < -120dB
Temperature Cycle	[±0.05%] -55°C 30minutes, +120°C 30minutes, 20cycles
Thermal EMF	0.05µV/°C
Soldering Heat	[±0.03%] 350°C, 3 sec.
Solvent	[No damage] IPA test
Solderability	[Covered 95%] 235°C, 2 sec.
Terminal Strength	[±0.05%]
Noise	< -43dB
Load Life	[±0.05%] 1000 hours

## ORDERING PROCEDURE EXAMPLE

Ordering Example	Model	TC	Resistance	Tolerance[%]	Code	Note
TP48Z100ohmB000	TP48	5ppm[Z]	100Ω	B [0.1]	000	1/4W, 2.54mm
TP48Y10kohmQ000	TP48	2ppm[Y]	10kΩ	Q [0.02]	000	1/4W, 2.54mm
TP46Z100ohmA000	TP46	5ppm[Z]	100Ω	A [0.05]	000	1/4W, 5.08mm
TP46Y10kohmQ000	TP46	2ppm[Y]	10kΩ	Q [0.02]	000	1/4W, 5.08mm
TP46C10kohmF000	TP46	50ppm[C]	10kΩ	F [1]	000	1/4W, 5.08mm

## DIMENSIONS(mm)

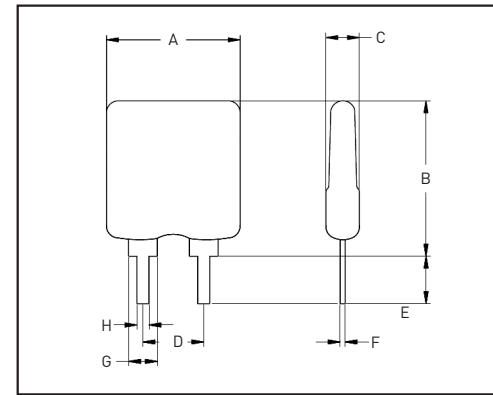

Model	TP48	TP47	TP46	TP45
A	5.6max	6.8max	8.0max	10.0max
B	8.2max	8.6max	9.0max	9.0max
C	2.54max	2.54max	2.54max	2.54max
D	2.54±0.25	3.81±0.25	5.08±0.25	7.62±0.25
E	3.3±0.5	3.3±0.5	3.3±0.5	3.3±0.5
F	0.25	0.25	0.25	0.25
G	1.25	1.2	1.2	1.2
H	0.5±0.05	0.5±0.05	0.5±0.05	0.5±0.05

## RESISTANCES, E24, E96

Standard Resistance E24+							Standard Resistance E96												
1.0	1.5	2.2	3.0	4.3	5.6	8.2	1.00	1.21	1.47	1.78	2.15	2.61	3.16	3.83	4.64	5.62	6.81	8.25	
1.1	1.6	2.4	3.3	4.7	6.2	9.1	1.02	1.24	1.50	1.82	2.21	2.67	3.24	3.92	4.75	5.76	6.98	8.45	
1.2	1.8	(2.5)	3.6	(5.0)	6.8		1.05	1.27	1.54	1.87	2.26	2.74	3.32	4.02	4.87	5.90	7.15	8.66	
1.3	2.0	2.7	3.9	5.1	7.5		1.07	1.30	1.58	1.91	2.32	2.80	3.40	4.12	4.99	6.04	7.32	8.87	
							1.10	1.33	1.62	1.96	2.37	2.87	3.48	4.22	5.11	6.19	7.50	9.09	
							1.13	1.37	1.65	2.00	2.43	2.94	3.57	4.32	5.23	6.34	7.68	9.31	
							1.15	1.40	1.69	2.05	2.49	3.01	3.65	4.42	5.36	6.49	7.87	9.53	
							1.18	1.43	1.74	2.10	2.55	3.09	3.74	4.53	5.49	6.65	8.06	9.76	

## TCR AND TOLERANCE IDENTIFICATIONS

TCR and Symbols		Tolerance and Symbols	
X	±1ppm/°C	T	±0.01%
Y	±2ppm/°C	Q	±0.02%
Z	±5ppm/°C	A	±0.05%
N	±10ppm/°C	B	±0.10%
E	±25ppm/°C	D	±0.50%
C	±50ppm/°C	F	±1.0%

# High Precision Resistors

High precision, matched pair SIP resistor networks utilizing NiCr thin film spattered on to an alumina substrate using high density patterning technologies. These models exhibit 1ppm 0.05%, tight ratio tolerance and TCR tracking (2T Series). The 2S and 2M models are economical and show good performance. A large variety of quick delivery resistances are available. The 2.5mm width and 5mm height is ideal for high density layouts. Application for 2S(wide) include: Voltage dividers, feed back resistors, voltage reference circuits in data processing, data transmission, precision power sources for industrial controls, medical and measurements.

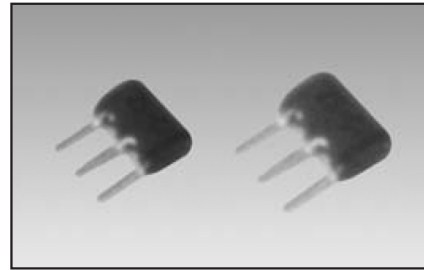

## GENERAL SPECIFICATIONS

Model	Resistance[Ω]		Tolerance(%)		TCR		Pin Configurations
	R1,#2,-#3	R2,#1,-#2	Absolute	Ratio	Absolute	Tracking	
2M-01, 2S-01	1K	1K	±1	0.1	±25ppm	5ppm	
2M-02, 2S-02	1K	10K	±1	0.1	±25ppm	5ppm	
2M-03, 2S-03	10K	10K	±1	0.1	±25ppm	5ppm	
2M-04, 2S-04	10K	20K	±1	0.1	±25ppm	5ppm	
2M-05, 2S-05	20K	20K	±1	0.1	±25ppm	5ppm	
2M-06, 2S-06	15K	15K	±1	0.1	±25ppm	5ppm	
2M-07, 2S-07	30K	30K	±1	0.1	±25ppm	5ppm	
2M-08, 2S-08	3K	680	±1	0.1	±25ppm	5ppm	
2M-09, 2S-09	2.2K	10K	±1	0.1	±25ppm	5ppm	
2M-10, 2S-10	50K	50K	±1	0.1	±25ppm	5ppm	
2M-11, 2S-11	30K	10K	±1	0.1	±25ppm	5ppm	
2M-12, 2S-12	60K	20K	±1	0.1	±25ppm	5ppm	
2M-13, 2S-13	18K	2K	±1	0.1	±25ppm	5ppm	
2M-14, 2S-14	1K	3K	±1	0.1	±25ppm	5ppm	
2M-15, 2S-15	1K	9K	±1	0.1	±25ppm	5ppm	
2M-17, 2S-17	3K	6K	±1	0.1	±25ppm	5ppm	
2M-18, 2S-18	2K	10K	±1	0.1	±25ppm	5ppm	
2T-01	1K	1K	±0.1	0.05	±5ppm	1ppm	
2T-02	1K	10K	±0.1	0.05	±5ppm	1ppm	
2T-03	10K	10K	±0.1	0.05	±5ppm	1ppm	
2T-04	10K	20K	±0.1	0.05	±5ppm	1ppm	
2T-05	20K	20K	±0.1	0.05	±5ppm	1ppm	
2T-06	15K	15K	±0.1	0.05	±5ppm	1ppm	
2T-07	30K	30K	±0.1	0.05	±5ppm	1ppm	
2T-08	3K	680	±0.1	0.05	±5ppm	1ppm	
2T-09	2.2K	10K	±0.1	0.05	±5ppm	1ppm	
2T-10	50K	50K	±0.1	0.05	±5ppm	1ppm	
2T-11	30K	10K	±0.1	0.05	±5ppm	1ppm	
2T-12	60K	20K	±0.1	0.05	±5ppm	1ppm	
2T-13	18K	2K	±0.1	0.05	±5ppm	1ppm	
2T-14	1K	3K	±0.1	0.05	±5ppm	1ppm	
2T-15	1K	9K	±0.1	0.05	±5ppm	1ppm	
2T-17	3K	6K	±0.1	0.05	±5ppm	1ppm	
2T-18	2K	10K	±0.1	0.05	±5ppm	1ppm	

## CHARACTERISTICS

Values in [ ] mean change in Ω after test

	2T	2S	2M	Condition
Rating Power/Element	125 mW	125 mW	125 mW	250mW / Package
Rated Ambient Temp.	70°C	70°C	70°C	
Operating Temp. Range	-55°C~125°C			
Insulation Resistance	10,000[MΩ]			
Dielectric Withstanding Voltage	±[0.1%+0.01Ω] 1000VAC, 60sec.			
Maximum Applied Voltage	[100V] Accordance with E= √P.R			
Short Time Overload	±[0.1%+0.01Ω] 2.5 times rated power, 5sec.			
Moisture Resistance	±[0.25%+0.01Ω] 60°C, 90-95RH, DC 0.1W, 1,000hours			
Soldering Heat	±[0.1%+0.01Ω] 350°C, 3sec.			
Load Life	±[0.1%+0.01Ω] 70°C, 90minutes on, 30minutes off, 1000hours			

## DIMENSIONS (mm)

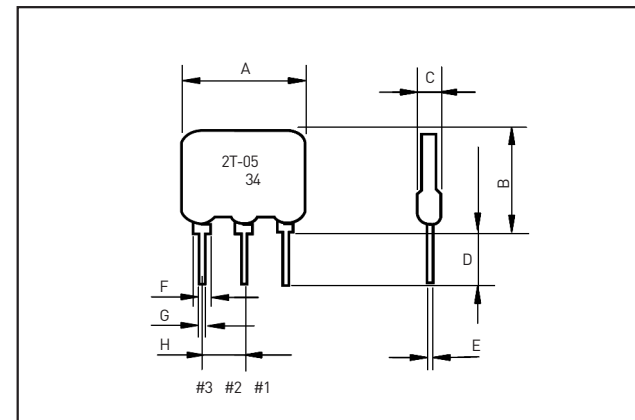

	2T	2S	2M
A	8.0max	8.0max	8.0max
B	5.0max	5.0max	7.0max
C	2.54max	2.54max	2.54max
D	3.3	3.3	3.3
E	0.25	0.25	0.25
F	1.2	1.2	1.2
G	0.5	0.5	0.5
H	2.54	2.54	2.54

## ORDERING PROCEDURE EXAMPLE

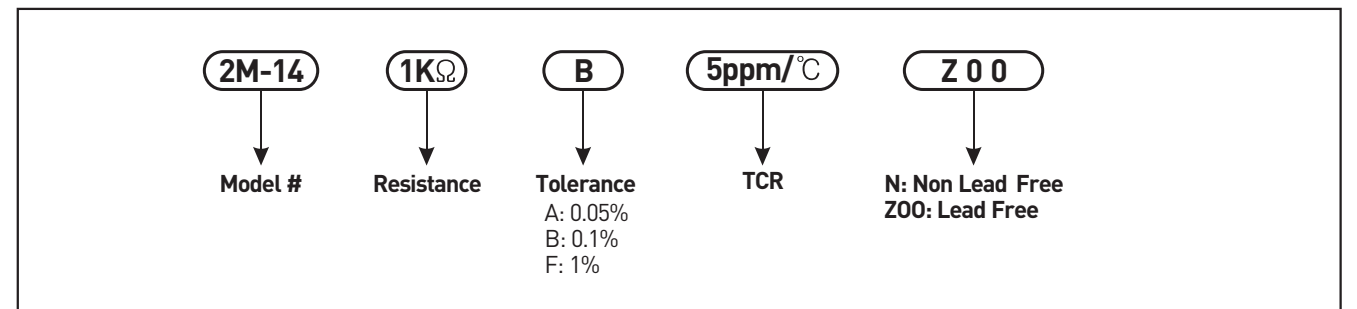

# Precision High Voltage Resistor

Features

- Resistance range from 10KΩ to 60MΩ
- Low TCR down to 25ppm/°C
- Tight tolerance down to ±0.1%
- Load life stability of 0.10% per 1,000 hours
- High operating voltage



## GENERAL SPECIFICATIONS

Type	Power Rating At 70 °C	Operating Temp Range	Max Operating Voltage	Max Overloading Voltage	Resistance Tolerance[%]	Resistance Range	TCR (ppm/°C)
PHV 2055	1W	-40 ~ +85 °C	1200V	1500V	[±0.10]	10KΩ~1MΩ	±25 ±50
					[±0.20]	10KΩ~40MΩ	
					[±0.25]		
					[±0.50]		
					[±1.0]		
PHV 2555	1W	-40 ~ +85 °C	1200V	1500V	[±0.10]	10KΩ~1.5MΩ	
					[±0.20]	10KΩ~50MΩ	
					[±0.25]		
					[±0.50]		
					[±1.0]		
PHV 3855	1W	-40 ~ +85 °C	1200V	1500V	[±0.10]	10KΩ~2MΩ	
					[±0.20]	10KΩ~60MΩ	
					[±0.25]		
					[±0.50]		
					[±1.0]		

## CHARACTERISTICS

Short Time Overload	ΔR±0.5%	JIS-C-5202-5.5/ RCWW×2.5 or maximum Overloading Voltage, 5sec.
Dielectric Withstand Voltage	By type	MIL-STD-202F Method 301/ Apply maximum Overload Voltage for 1minute
Insulation Resistance	> 1000MΩ	MIL-STD-202F Method 302/ Apple 100VDC for 1minute
Thermal Shock	ΔR±0.25%	MIL-STD-202F Method 107G/ -55°C~150°C, 100cycles
Load Life	ΔR±0.5%	MIL-STD-202F Method 108A/ RCWW, 70 °C, 1.5hours on, 0.5hours off Total 1000~1048hours
Humidity(Steady State)	ΔR±0.3%	MIL-STD-202F-Method 103B/ 40 °C, 90~95%RH, RCWW 1.5hours on, 0.5hours off Total 1000~1048hours
Resistance to Dry Heat	ΔR±0.2%	JIS-C-5202-7.2/ 96hours at +155 °C without load
Low Temperature Operation	ΔR±0.2%	JIS-C-5202-7.1/ 1hours, -65 °C, followed by 45minutes of RCWW
Bending Strength	ΔR±0.2%	JIS-C-5202-6.1.4/ Bending Amplitude 3minimum for 10sec.
Solderability	90% minimum coverage	MIL-STD-202F Method 208H/ 245 °C±5°C, 3±0.5(sec.)
Resistance to Soldering Heat	ΔR±0.2%	MIL-STD-202F Method 210E/ 260±5°C, 10±1sec.

## DIMENSIONS [mm]

Type	A	B	C	D	E	F	G(Max)	H(Max)
2055	20±0.5	5.5±0.5	0.5	1.4	17.78±0.5	3.3±0.7	2.0	7.5
2555	25.4±0.5	5.5±0.5	0.5	1.4	22.86±0.5	3.3±0.7	2.0	7.5
3855	38.1±0.5	5.5±0.5	0.5	1.4	35.56±0.5	3.3±0.7	2.0	7.5

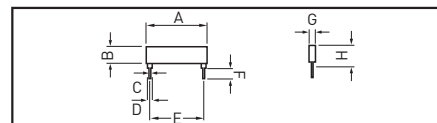

## ORDERING PROCEDURE EXAMPLE

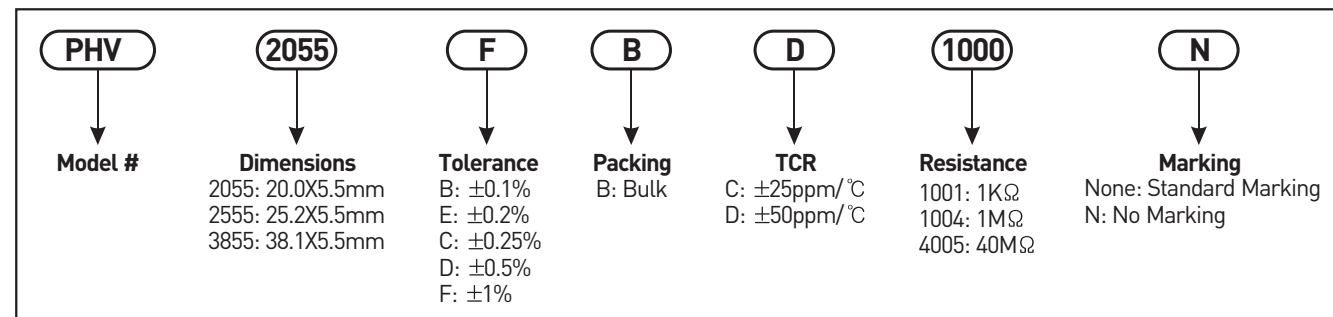

# Thin Film Precision High Wattage Resistor

Features

- High power rating up to 3 Watts
- Resistance range from 5Ω to 10KΩ
- Low TCR down to ±15ppm/°C
- Tight tolerance down to ±0.1%

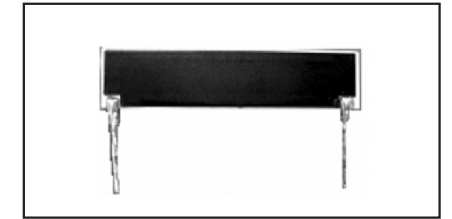

## GENERAL SPECIFICATIONS

Type	Power Rating at 70 °C[W]	Operating Temp Range	Max Operating Voltage	Max Overloading Voltage	Resistance Tolerance[%]	Resistance Range	TCR (ppm/°C)
PHW2500	3W	-40 ~ +85 °C	200V	400V	[±0.10]	5Ω~10KΩ	±15 ±25 ±50
					[±0.25]		
					[±0.50]		
					[±1.00]		

## CHARACTERISTICS

Short Time Overload	ΔR±0.5%	JIS-C-5202-5.5 RCWW×2.5 or maximum Overloading Voltage, 5sec.
Dielectric Withstand Voltage	By type	MIL-STD-202F Method 301 Apply maximum Overload Voltage for 1minute
Insulation Resistance	> 1000MΩ	MIL-STD-202F Method 302 Apple 100VDC for 1minute
Thermal Shock	ΔR±0.25%	MIL-STD-202F Method 107G -55°C~150°C, 100cycles
Load Life	ΔR±0.5%	MIL-STD-202F Method 108A RCWW, 70 °C, 1.5hours on, 0.5hours off Total 1000~1048hours
Humidity(Steady State)	ΔR±0.3%	MIL-STD-202F-Method 103B 40 °C, 90~95%RH, RCWW 1.5hours on, 0.5hours off Total 1000~1048hours
Resistance to Dry Heat	ΔR±0.2%	JIS-C-5202-7.2 96hours at +155 °C without load
Low Temperature Operation	ΔR±0.2%	JIS-C-5202-7.1 1hours, -65 °C, followed by 45minutes of RCWW
Bending Strength	ΔR±0.2%	JIS-C-5202-6.1.4 Bending Amplitude 3minimum for 10sec.
Solderability	90% minimum coverage	MIL-STD-202F Method 208H 245 °C±5°C, 3±0.5(sec.)
Resistance to Soldering Heat	ΔR±0.2%	MIL-STD-202F Method 210E 260±5°C, 10±1sec.

## DIMENSIONS [mm]

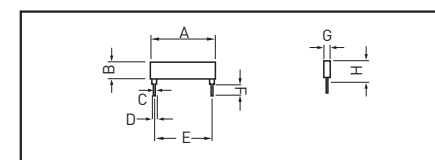

Type	A	B	C	D	E	F	G	H
PHW2500	28±0.2	6.35±0.2	0.5	1.4	25±0.5	3.3±0.7	0.55±0.1	8.5Max

## ORDERING PROCEDURE EXAMPLE

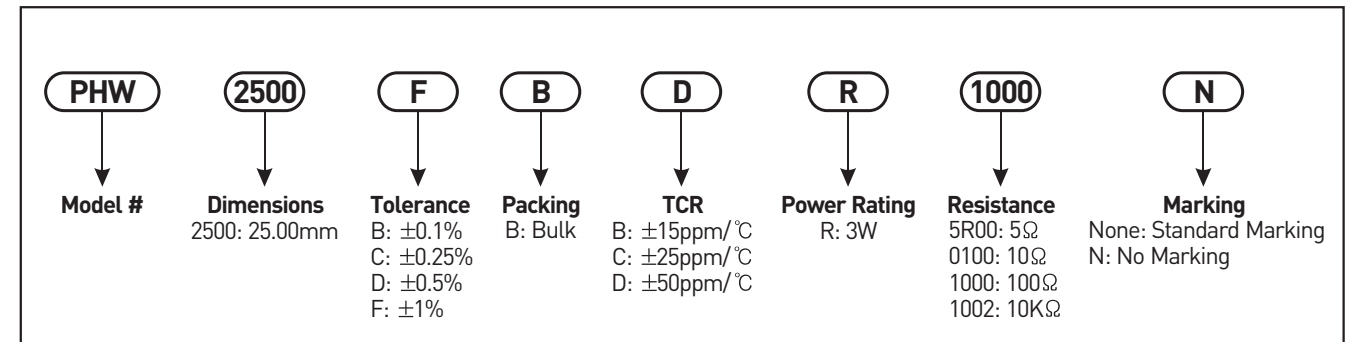

# Precision Wirewound Resistors

5G10 are only 7.94mm long with a diameter of 3.97mm, yet they incorporate advanced design and manufacturing features which provide unsurpassed accuracy, stability, and reliability. Each 5G10 undergoes three separate complete tests during manufacture including an accelerated aging thermal shock procedure.

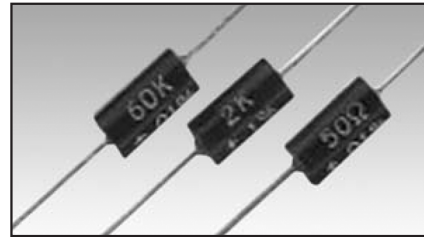

## GENERAL SPECIFICATIONS

Model	Power Rating [W]	Max Voltage [V]	Resistance Range[Ω]		Tolerance at 25°C(%)
			Standard	Non-Standard	
5G10A	0.2 (+85°C)	175	10Ω to 100KΩ	10Ω to 200KΩ	[±0.01]
5G10D	0.14 (+110°C)	DC or AC peak			[±0.1]

## CHARACTERISTICS

Temp. Coefficient	±3ppm/°C typical over 0°C to +85°C, ±5ppm/°C maximum over -55°C to +125°C
Thermal EMF	< 0.4µV/°C typical
Noise	Essentially non-measurable
Encapsulation	Moulded epoxy
Leads	24 AWG tinned copper
No Load Stability	±25ppm/10,000 hours, ±35ppm/26,000 hours. (over full temperature range; -55°C ~ +125°C)
Full Load Stability	±35ppm / 10,000 hours, ±50ppm / 26,000 hours

## DIMENSIONS(mm)

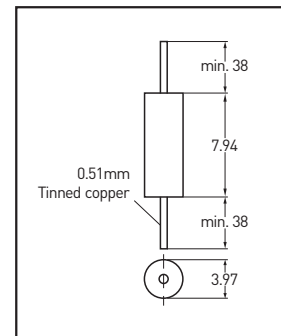

## ORDERING PROCEDURE EXAMPLE

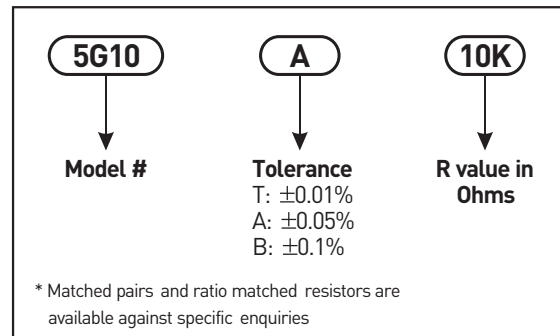

## DERATING CURVES

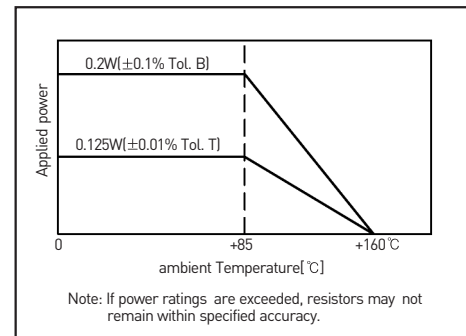

## STANDARD RESISTANCE VALUES

Stocked in 0.1% in listed value shown below					
10Ω	180Ω*	680Ω*	3.3K*	12K*	60K
20Ω	200Ω	700Ω	3.9K*	15K*	68K
30Ω	220Ω*	800Ω	4.0K	18K*	70K
40Ω	250Ω	820Ω*	4.7K*	20K	80K
50Ω	270Ω*	900Ω	5.0K	22K*	82K
60Ω	300Ω	1.0K	5.6K*	25K	90K
62.5Ω*	330Ω*	1.2K*	6.0K	27K*	99K
70Ω	350Ω	1.5K	6.8K*	30K	100K
80Ω	390Ω*	1.8K*	7.0K	33K*	
90Ω	400Ω	2.0K	8.0K	37K	
100Ω	470Ω*	2.2K*	8.2K*	40K	
120Ω	500Ω	2.5K	9.0K	47K*	
125Ω*	560Ω*	2.7K*	9.9K*	50K	
150Ω*	300Ω	3.0K	10.0K	56K*	

Any non-listed value from 10Ω to 200KΩ available to order

\* Stocked in 0.1% tolerance only

# Precision Wirewound Resistors

8G16 and 8G24 are high precision wirewound resistors, providing excellent stability over temperature and time. They use balanced multiple π, low reactance windings employing an exclusive "air cushion" technique, providing virtually stress free elements. They are "non-inductively" wound with the direction of winding reversed at the half turns point. Econistors are suitable for most analogue precision circuits, e.g, gain setting, bridge balancing, voltage dividing, referencing, etc.

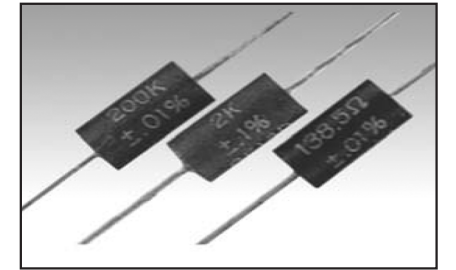

## GENERAL SPECIFICATIONS

Model	Power Rating [W]	Max Working Voltage[V]	Resistance Range[Ω]		Tolerance at 25°C(%)
			Standard	Non-Standard	
8G16	0.33W(+85°C)	Up to 250V DC or peak as determined by √P*R	1Ω to 1MΩ	1Ω to 1.1MΩ	[±0.005]
8G24	0.25W(+110°C)		Type 8G 16 < 700kΩ Type 8G 24 > 700kΩ		[±0.01]
					[±0.1]

\* 0.005% available on values of 100Ω and above only

## CHARACTERISTICS

Temp. Coefficient	±3ppm/°C typical over 0°C to +85°C, ±5ppm/°C maximum over -55°C to +125°C
Thermal EMF	< 0.4µV/°C typical, < 1.5µV/°C maximum
Noise	Essentially non-measurable
Encapsulation	Moulded epoxy
Leads	24 AWG tinned copper
No Load Stability	±25ppm/10,000 hours, ±35ppm/26,000 hours. (over full temperature range; -55°C ~ +125°C)
Full Load Stability	±35ppm / 10,000 hours, ±50ppm / 26,000 hours

## DIMENSIONS(mm)

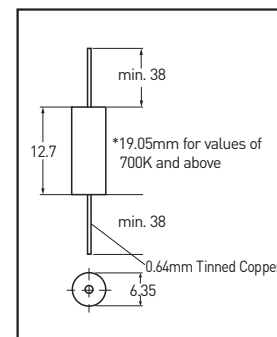

## ORDERING PROCEDURE EXAMPLE

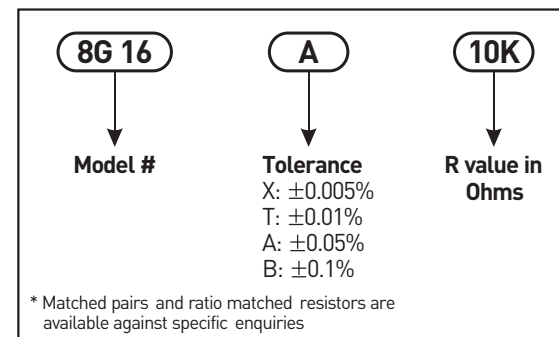

## DERATING CURVES

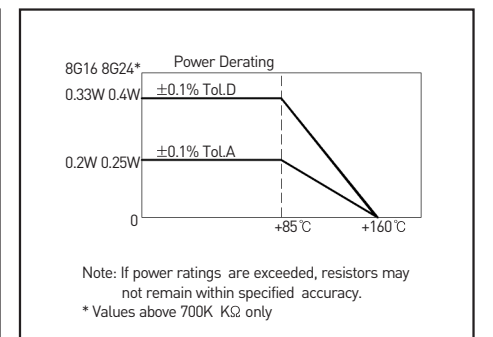

## STANDARD RESISTANCE VALUES

1Ω	103.90Ω**	194.07Ω**	680Ω*	4.7K*	27K*	180K
2Ω	107.79Ω**	200.00Ω	700Ω	5.0K	30K	200K
5Ω	109.73Ω**	212.02Ω**	800Ω	5.6K*	33K*	250K
10Ω	111.67Ω**	220.00Ω*	820Ω*	6.0K	39K	300K
20Ω	115.54Ω**	229.67Ω**	900Ω	6.8K*	40K	320K*
30Ω	119.40Ω**	247.04Ω**	1.0K	7.0K	47K*	400K
40Ω	120.00Ω	250Ω	1.2K*	8.0K	50K	500K
50Ω	123.24Ω**	270Ω*	1.5K	8.2K*	56K*	990K
60Ω	125.00Ω**	300Ω	1.8K*	9.0K	60K	1M
60.25Ω**	127.07Ω**	330Ω*	2.0K	9.9K	68K*	
62.50Ω*	130.89Ω**	350Ω	2.2K	10.0K	70K	
70Ω	134.70Ω**	390Ω*	2.5K	12.0K*	80K	
80Ω	138.50Ω	400Ω	2.7K*	15.0K*	82K*	
84.27Ω**	150.00Ω*	470Ω*	3.0K	18.0K*	90K	
90Ω	157.31Ω**	500Ω	3.3K*	20.0K	99K	
92.16Ω**	175.84Ω**	560Ω*	3.9K*	22.0K*	100K	
100Ω	180.00Ω*	600Ω	4.0K	25.0K	160K*	

Any non-listed value from 1Ω to 1.1MΩ available to order

\* Stocked in ±0.1% tolerance only. \*\*Stocked in ±0.01% tolerance only.

## ±3ppm/°C, 0.01% Precision Wirewound Resistors

GG102 are miniature precision wirewound resistors in compact, rectangular, space-saving shape. Specifically designed for PC board mounting they have radial leads and are enclosed in a molded epoxy case giving the exact uniformity of size required for high density PC board assembly. Each resistor undergoes multiple complete tests during manufacture including an accelerated aging and thermal shock procedure.

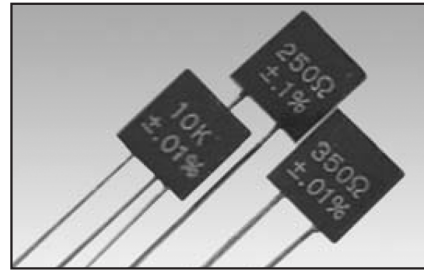

### GENERAL SPECIFICATIONS

Model	Power Rating [W]	Max. Applied Voltage[V]	Resistance Range[Ω]	Tolerance at 25 °C[%]
GR102A (GG102A)	0.3W (+85°C) See diagram of Power Derating Curves	150V DC or AC peak	1Ω-250kΩ	±0.01
GR102D (GG102D)				±0.1

\*Please note: RoHS compliant parts are now green and the second letter in the part number is 'G'

### CHARACTERISTICS

Temp. Coefficient	±3ppm/°C typical over 0 °C to +85 °C, ±5ppm/°C maximum over -55 °C to +125 °C
Thermal EMF	< 0.4 μV/°C typical
Noise	Essentially non-measurable
Encapsulation	Moulded epoxy
Leads	22 AWG tinned copper
No Load Stability	±25ppm/10,000 hours, ±35ppm/26,000 hours. over full temp. -55 °C to +125 °C
Full Load Stability	±35ppm/10,000 hours, ±50ppm/26,000 hours.

### DIMENSIONS(mm)

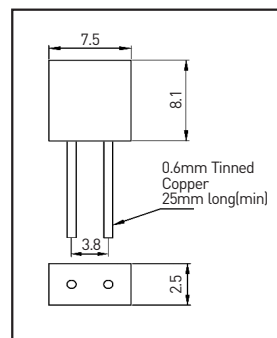

### ORDERING PROCEDURE EXAMPLE

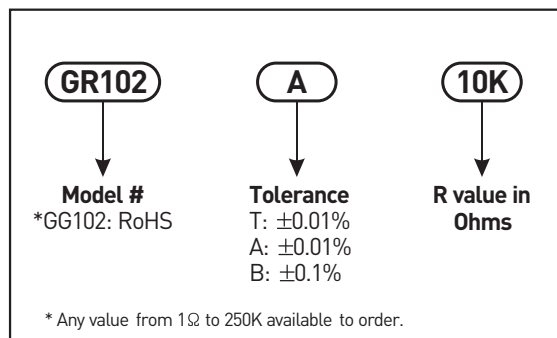

### DERATING CURVES

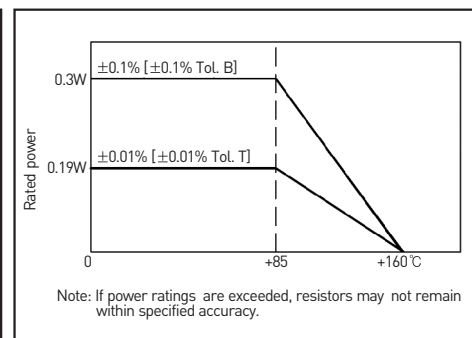

### STANDARD RESISTANCE VALUES

Stocked in 0.1% in listed value shown below				
10 Ω	120 Ω	900 Ω	8 K	180 K
20 Ω	200 Ω	1 K	9 K	90 K
30 Ω	250 Ω	1.5 K	10 K	100 K
40 Ω	300 Ω	2 K	20 K	250 K
50 Ω	350 Ω	2.5 K	25 K	
60 Ω	400 Ω	3 K	30 K	
70 Ω	500 Ω	4 K	40 K	
80 Ω	600 Ω	5 K	50 K	Any non-listed value from 10Ω to 250KΩ available to order
90 Ω	700 Ω	6 K	60 K	
100 Ω	800 Ω	7 K	70 K	

## Test Resistors

These competitive and very high precision resistors are used for calibrating and checking instrumentation. Constructed with the highest quality resistance wire. Excellent long term stability and tight tolerance. Two and four terminal styles available.

- Max. 0.5W
- Tolerance: 0.01%
- T.C.R: 5ppm/°C



### GENERAL SPECIFICATIONS

Model	Power Rating [W]	Terminal	Standard Resistance [Ω]	Tolerance[%] at 23±1°C	Temp. Coefficient 23-40°C	Operating Temp	Aged Deterioration [ppm/year]
5340-01	0.5W/Max. 10sec 0.1W/10sec over	4	1m	±0.02	±30ppm/°C	0 ~ 40°C	Max. 20
5340-02			10m		±10ppm/°C		
5340-03			100m		±0.01		±5ppm/°C
5340-04			1				
5340-05			10				
5340-06			100				
5340-07			1K				
5340-08			10K				
5340-09			2	100K	±10ppm/°C		Max. 10

The max. Power is 0.1W when you use it for longer than 10 seconds

### DIMENSIONS [mm]

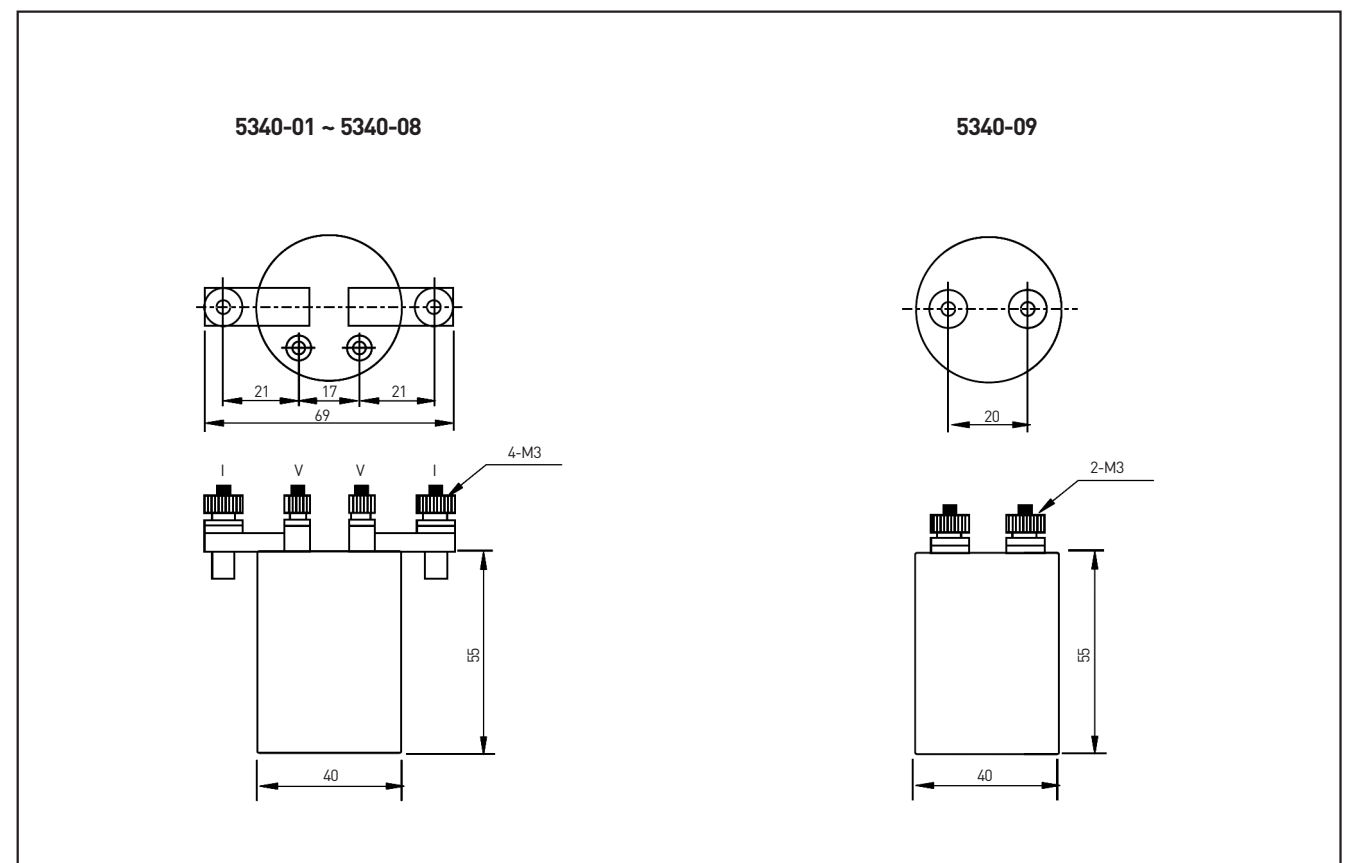

# TO126 5W Precision Power Resistor

TNP10P are super-precision power resistors. These models come in TCRs of 10(N), 5(Z) and 2(Y)ppm/°C. Available tolerances of 0.1%(B) and 0.05%(A) are available at operating temperatures of 0~+120°C. Rated power is 5W if attached to circuit board Cu foil and 1W unattached. Excellent for low noise, high frequency and high density jobs. Applications include: Constant current sources for electronic load circuit, LSI tests, measurements, PA systems and motor control.

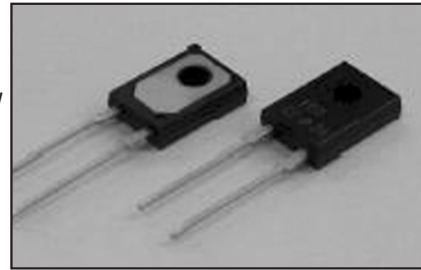

## GENERAL SPECIFICATIONS

Resistance Range[Ω]	0.1 ~ 0.99	1 ~ 5	5~51K
TCR [PPM/°C]	±25	±5, ±10, ±25	±5, ±10, ±25
Tolerance	1%, 2%, 5%	0.5%, 1%	0.05%, 0.1%, 0.25%, 0.5%
Nominal Resistance	E24 and any values		
Operation Temp. Range	-55 to +155 °C		
Rating Temperature	+25 °C		
Power Rating	5W [-55 °C to 25 °C flange temperature], 0.5w(in free air)		
Heat Resistance	6.0 °C/W		
Max Operating Voltage	300V or $\sqrt{P \cdot R}$		
Inductance	9nH		
Capacitance	1pF		

## CHARACTERISTICS

Insulation Resistance	[Over 1,000MΩ]	Between terminals and flange.
Dielectric Withstanding Voltage		DC2000V for 60sec.
Short Time Overload	±[0.25%+0.05Ω]	Rating power×2.5, 5 sec, with heat sink.
Moisture Resistance	±[1.0%+0.05Ω]	60 °C, 90~95%RH, DC 0.1W, 1000 hours.
Temp. Cycle	±[0.25%+0.05Ω]	-55 °C, 30 minutes, +120 °C, 30 minutes, 5cycles
Vibration	±[0.25%+0.05Ω]	JISC5202
Soldering Heat	±[0.1%+0.05Ω]	350 ±5 °C, 3 sec.
Solderability	Over 3/4 of surface	230 ±5 °C, 3 sec.
Terminal Strength	±[0.25%+0.05Ω]	Tension 4.9N, 1~5 secs. Bend 2.45N, 90 °C, 2 times.
Load Life	±[1.0%+0.05Ω]	25 °C, 90 minutes on, 30 minutes off, 1000 hours

## DIMENSIONS [mm] AND STRUCTURE

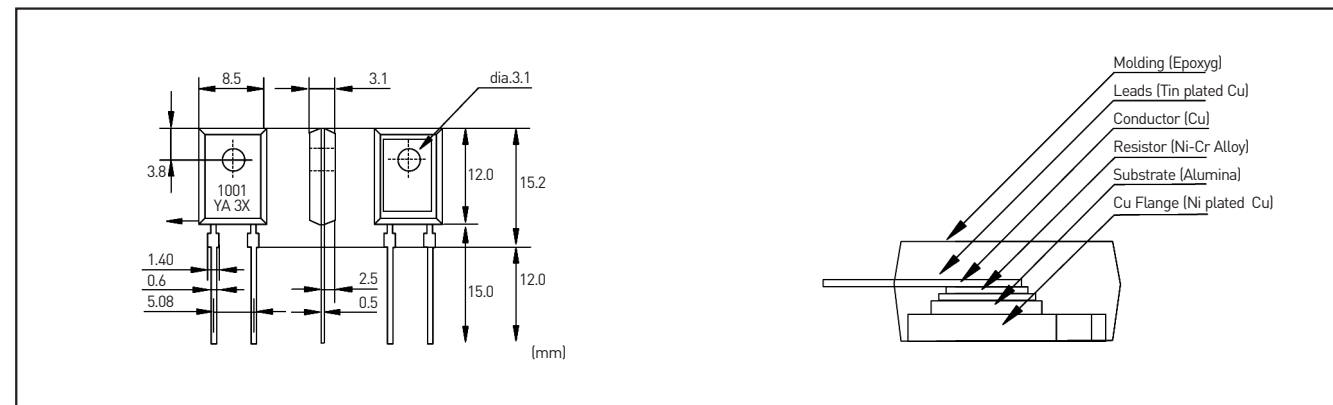

## DERATING CURVE AND TEMPERATURE RISE

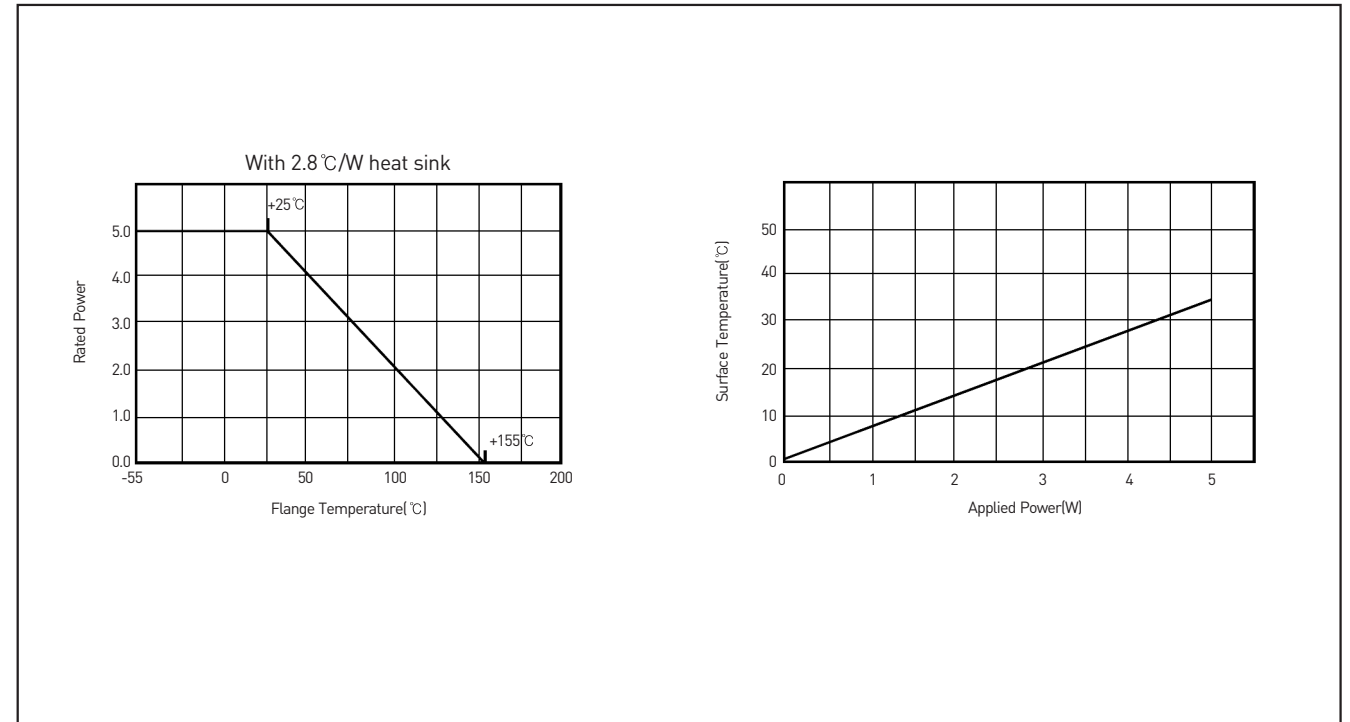

## ORDERING PROCEDURE EXAMPLE

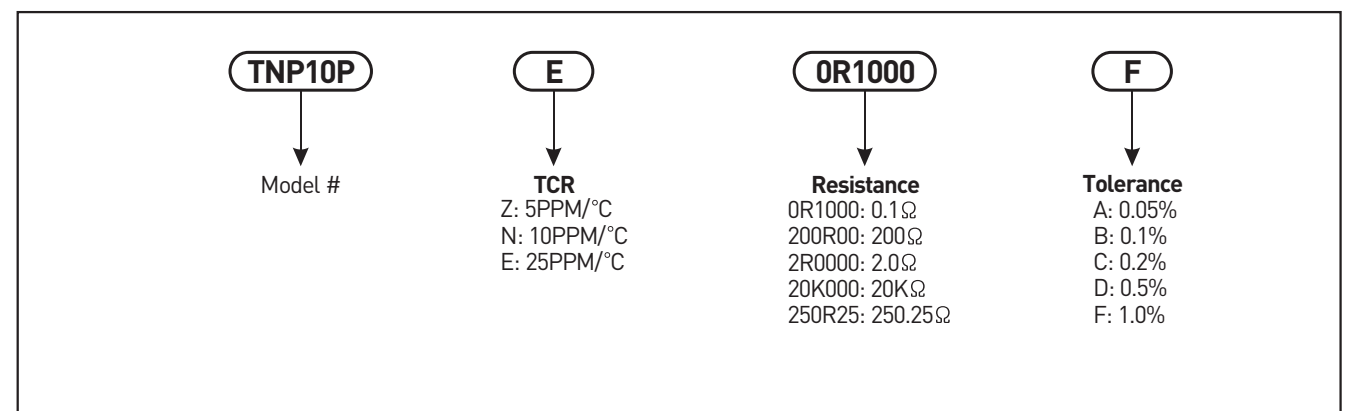

# TO220 10W Precision Power Resistors

TNP20P are precision power resistors. Tolerances of 0.1%(B) and TCRs of 5ppm/°C are available. Rated power is 10W if attached to metal case or heatsink. Using thin film technology these units have a proportional temperature vs. small resistance changes between -55°C and +120°C. In DC ranges of up to 100MHz these components are non-inductive and noncapacitive. Units come with a 2KV withstanding voltage between circuit and flange. Applications include: AC power supplies, testing equipment, UPS, motor control, electronics loads, high frequency power supply, 50Ω terminations, high frequency adjustment resistors and Wilkinson amplifiers.

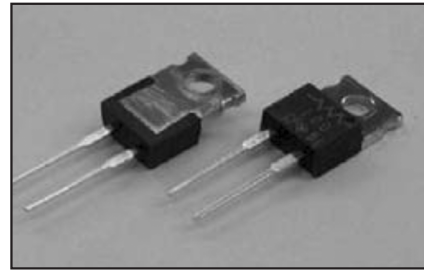

## GENERAL SPECIFICATIONS

Resistance Range[Ω]	0.1 ~ 0.99	1 ~ 5	5-51K
TCR[PPM/°C]	±25	±5, ±10, ±25	±5, ±10, ±25
Tolerance	F(±1%), G(±2%), J(±5%)	D(±0.5%), F(±1%)	A(±0.05%), B(±0.1%), C(±0.25%), D(±0.5%)
Nominal Resistance	E24 and any values		
Operation Temp. Range	-55 to +155 °C		
Rating Temperature	+25 °C		
Power Rating	10W (-55 °C to 25 °C flange temperature)		
Heat Resistance	3.3 °C/W		
Max Operating Volt.	500V or $\sqrt{P \cdot R}$		
Inductance	10nH		
Capacitance	1pF		

## CHARACTERISTICS

Insulation Resistance	[Over 1,000MΩ]	Between terminals and flange.
Dielectric Withstanding Voltage		DC2000V for 60 sec.
Short Time Overload	±[0.25%+0.05Ω]	Rating power × 2.5, 5 sec, with heat sink.
Moisture Resistance	±[1.0%+0.05Ω]	60 °C, 90-95%RH, DC 0.1W, 1000 hours.
Temp. Cycle	±[0.25%+0.05Ω]	-55 °C, 30 minutes, +120 °C, 30 minutes, 5 cycles
Vibration	±[0.25%+0.05Ω]	±JISC5202
Soldering Heat	±[0.1%+0.05Ω]	350 °C ± 5 °C, 3 sec.
Solderability	[Over 3/4 of surface]	230 °C ± 5 °C, 3 sec.
Terminal Strength	±[0.25%+0.05Ω]	Tension 4.9N, 1-5 sec. Bend 2.45N, 90 °C, 2 times.
Load Life	±[1.0%+0.05Ω]	25 °C, 90 minutes on, 30 minutes off, 1000 hours

## DIMENSIONS [mm] AND STRUCTURE

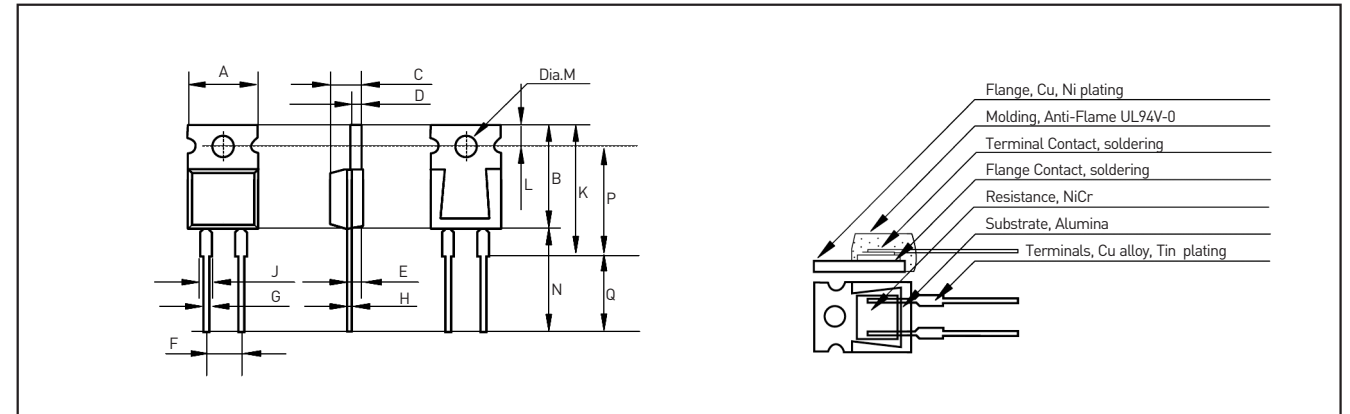

A	B	C	D	E	F	G	H	J	K	L	M	N	P	Q
10.0±0.2	15.0±0.2	4.5±0.2	1.5±0.1	2.45±0.2	5.08±0.5	0.75	0.50	1.5	19.0	2.7±0.5	3.6 dia.	15.0 min.	16.0±0.5	11.0 min.

## DERATING CURVE AND TEMPERATURE RISE

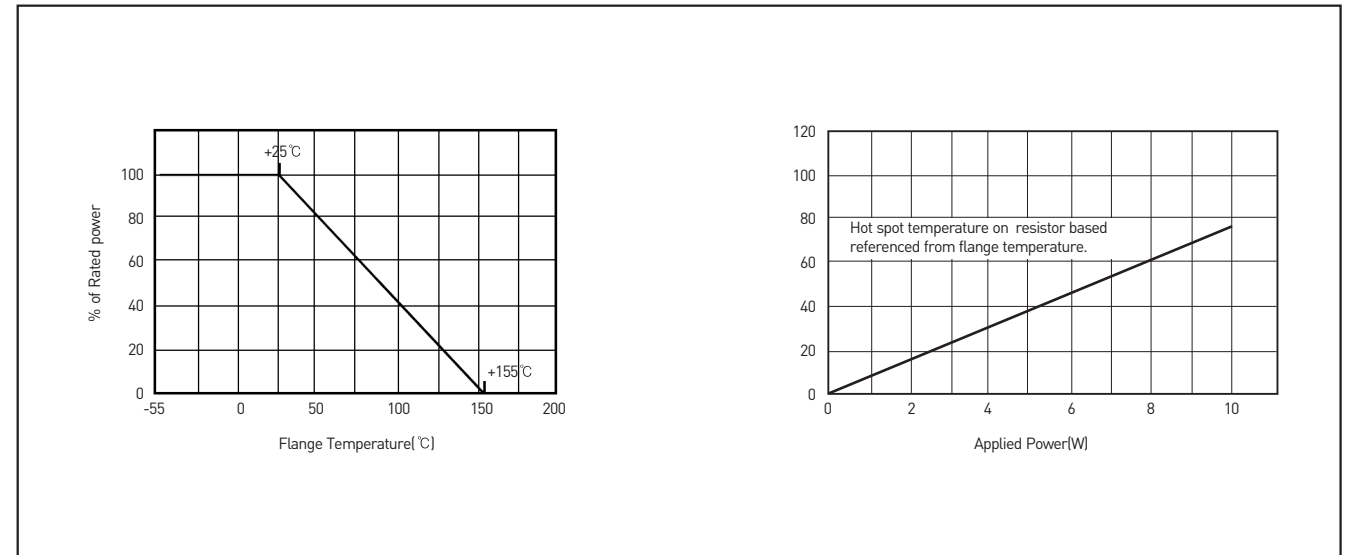

## ORDERING PROCEDURE EXAMPLE

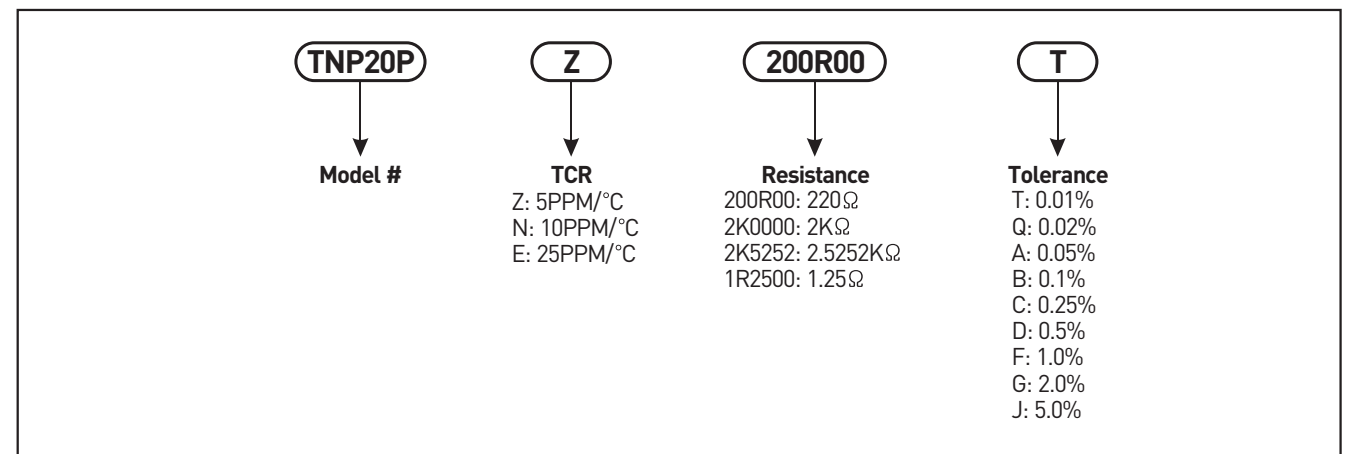

# Precision Wire Wound Resistors

- Max: 1.2W
- Tolerance: 0.005%
- TCR: 5ppm/°C

## GENERAL SPECIFICATIONS

Model	Power Rating[W]	Resistance Range[Ω]	Resistance Tolerance(%)	Max Voltage[V]	Operating Temp.	Temp Coefficient
PH04	0.4	1 ~ 56K	$V \left[ \begin{matrix} \pm 0.005 \\ R > 50\Omega \end{matrix} \right]$ $T \left[ \begin{matrix} \pm 0.01 \\ R > 10\Omega \end{matrix} \right]$ $A \left[ \begin{matrix} \pm 0.05 \\ R \geq 1\Omega \end{matrix} \right]$	200	-30°C~ +100°C	$\left( \begin{matrix} \pm 5\text{ppm}/^\circ\text{C} \\ R \geq 10\Omega \end{matrix} \right)$ $\left( \begin{matrix} \pm 10\text{ppm}/^\circ\text{C} \\ R < 10\Omega \end{matrix} \right)$
PH06	0.6	1 ~ 80K				
PH10	1.0	1 ~ 300K				
PH12	1.2	1 ~ 500K				
T56E	0.125	10 ~ 27K	$T \left[ \begin{matrix} \pm 0.01 \\ R > 50\Omega \end{matrix} \right]$ $A \left[ \begin{matrix} \pm 0.05 \\ R > 10\Omega \end{matrix} \right]$	150	-30°C~ +100°C	±5ppm/°C
T55E	0.25	10 ~ 56K				
T53E	0.5	10 ~ 180K				
C0603E	0.1	0.1 ~ 30K	$Q \left[ \begin{matrix} \pm 0.02 \\ A \left[ \begin{matrix} \pm 0.05 \\ R > 10\Omega \end{matrix} \right] \\ R > 10\Omega \end{matrix} \right]$ $B \left[ \begin{matrix} \pm 0.1 \\ R \geq 1\Omega \end{matrix} \right]$	60	-65°C~ +145°C	$\left( \begin{matrix} \pm 20\text{ppm}/^\circ\text{C} \\ R \geq 10\Omega \end{matrix} \right)$ $\left( \begin{matrix} \pm 50\text{ppm}/^\circ\text{C} \\ 10\Omega > R \geq 1\Omega \end{matrix} \right)$ $\left( \begin{matrix} \pm 90\text{ppm}/^\circ\text{C} \\ 1\Omega > R \geq 0.1\Omega \end{matrix} \right)$
C0806E	0.125	0.1 ~ 125K				
C1306E	0.15	0.1 ~ 225K				
C2610E	0.4	0.1 ~ 1.2M				
C2613E	1.0	0.1 ~ 1.5M				
C0806L	0.125	0.1 ~ 20K				
C1310L	0.25	0.1 ~ 240K				
C1910L	0.33	0.1 ~ 450K				

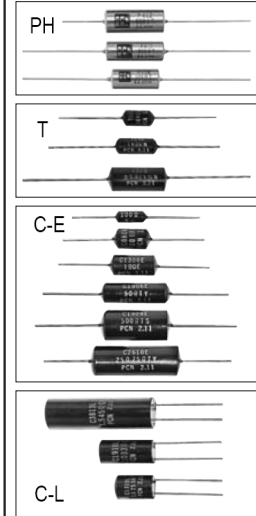

## CHARACTERISTICS

Test	Limit			Conditions
	C-E, C-L Series	T Series	PH Series	
Insulation Resistance	≥1000MΩ	≥1000MΩ	≥1000MΩ	DC 500V
Dielectric Withstanding voltage	±(0.05%+0.05Ω)	±0.02%	±0.005%	AC 1000V 1minute
Short Time Overload	±(0.1%+0.05Ω)	±0.05%	±0.005%	2 x wattage rating 10minutes
Temperature Cycling	±(0.2%+0.05Ω) ※1: 125°C	±0.02% ※2: 70°C	±0.01% ※3: 85°C	-30 (30minutes)~Normal Temp. (15minutes) ~ ※1, ※2, ※3(30minutes) ~ Normal Temp.(15minutes) Repeat 5cycles
Load Life	±(0.5%+0.05Ω) ※4: 125°C	±0.05% ※5: 70°C	±0.01% ※6: normal temp	Wattage rating ( ※4, ※5, ※6) 1500hours

\* Note1: Other resistance will be available, please call factory

## ORDERING PROCEDURE EXAMPLE

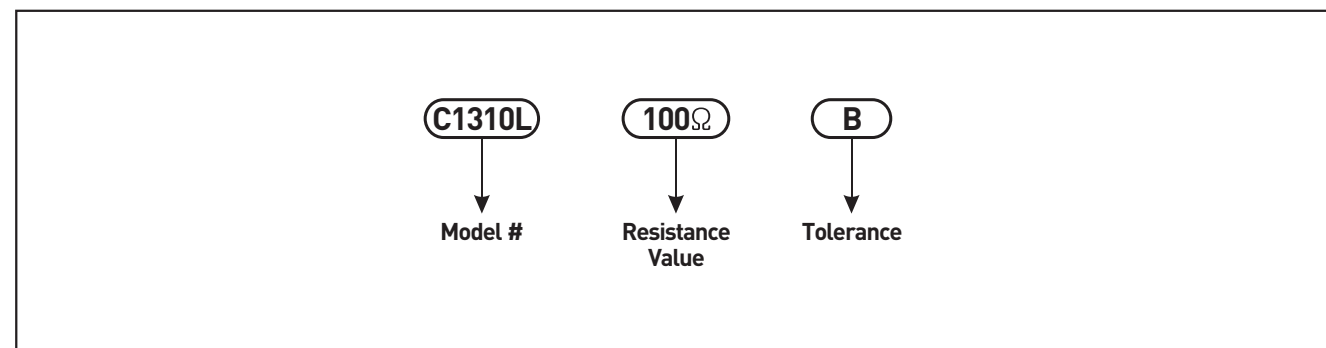

## DERATING CURVES

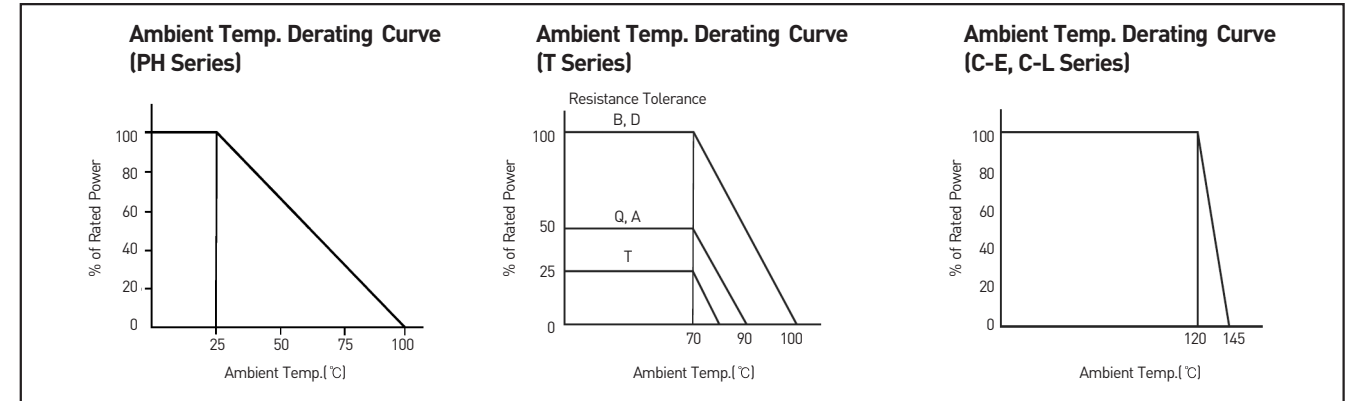

## DIMENSIONS (mm)

Model	L(mm)	D(mm)	d(mm)
PH04	17	7.5	0.8
PH06	23	7.5	0.8
PH10	30	10.5	0.8
PH12	31	12.5	0.8
T56E	11	6.8	0.9
T55E	15	6.8	0.9
T53E	20	10	0.9
C0603E	10	4	0.6
C0806E	10	7	0.8
C1306E	15	7	0.8
C2610E	28	10	0.8
C2613E	28	13	0.8
C0806L	8	6.8	0.6
C1310L	13	10	0.8
C1910L	19	10	0.8

PH, T, C-E Series

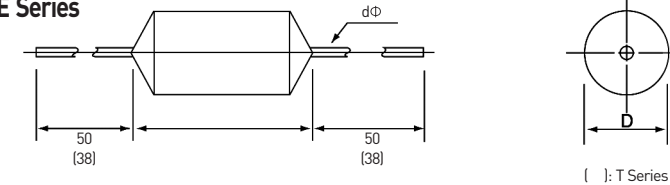

C-L Series

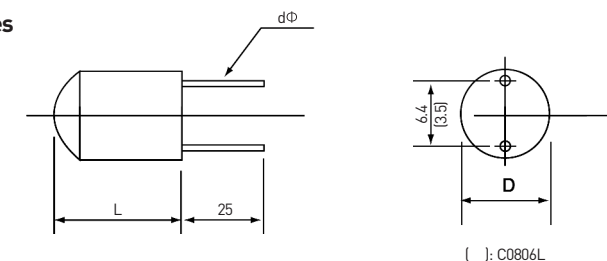

Model	Resistance Range[Ω]	Maximum Working Voltage[V]	Ambient Power Rating		Dimensions (mm)	Resistance Tolerance % VS. Lowest Resistance Value [Ω]
			@+70°C	@+125°C		
S102C (S102J) <sup>(2)</sup>	1 to 150K	300	0.6W	0.3W (up to 100k)	W: 2.67±0.25 L: 7.62±0.25 H: 8.28±0.25 ST: 0.254 minimum	±0.005 / 50 ±0.01 / 25 ±0.02 / 12 ±0.05 / 5 ±0.1 / 2 ±0.5 / 1
S102K (S102L) <sup>(2)</sup>	1 to 100K		0.4W	0.2W (over 100k)	SW: 1.02±0.13 LL: 25.4±3.18 LS: 3.81±0.13	
S104D (S104F) <sup>(1)</sup>	1 to 500K	350	1W	0.5W (up to 200k)	W: 4.06 maximum L: 14.61 maximum H: 10.49 maximum ST: 0.889±0.13	
S104K	1 to 300K		0.6W	0.3W (over 200k)	SW: 1.27±0.13 LL: 25.4±3.18 LS: 10.16±0.51	
S105D (S105F) <sup>(1)</sup>	1 to 750K	350	1.5W	0.75W (up to 300k)	W: 4.06 maximum L: 20.83 maximum H: 10.49 maximum ST: 0.889±0.13	
S105K	1 to 500K		0.8W	0.4W (over 300k)	SW: 1.27±0.13 LL: 25.4±3.18 LS: 16.51±0.51	
S106D	0.5 to 1M	500	2.0W	1.0W (up to 400k)	W: 6.60 maximum L: 30.48 maximum H: 10.49 maximum ST: 0.889±0.13	
S106K	0.5 to 600K		1.0W	0.5W (over 400k)	SW: 1.27±0.13 LL: 25.4±3.18 LS: 22.86±0.51	

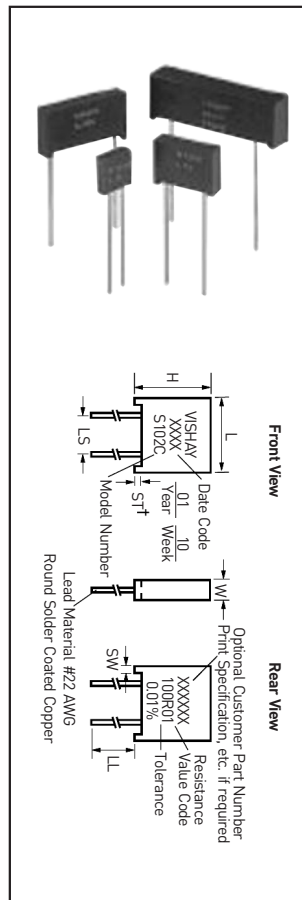

(1) S104F and S105F have different package dimensions  
 (2) 5.08mm lead spacing available - specify S102J for S102C, and S102L for S102K

Model	Resistance Range[Ω]	Maximum Working Voltage[V]	Ambient Power Rating		Dimensions (mm)	Max. TCR of Resistance [+25°C Ref.]	Load-life Stability (MAXIMUM ΔR)
			@+70°C	@+125°C			
VSR VSRJ <sup>(1)</sup>	1 to 150K	300	0.3W	0.2W (up to 100k) 0.2W 0.1W (over 100k)	W: 2.67±0.25 L: 7.62±0.25 H: 8.28±0.25 ST: 0.254 minimum SW: 1.02±0.13 LL: 25.4±3.18 LS: 3.81±0.13	0°C to +60°C ±4ppm/°C -50°C to +125°C ±8ppm/°C	0.05% 2000 hours at +125°C
VSR4	1 to 500K	350	0.5W	0.4W (up to 200k) 0.25W 0.2W (over 200k)	W: 4.06 maximum L: 14.61 maximum H: 10.49 maximum ST: 0.889±0.13 SW: 1.27±0.13 LL: 25.4±3.18 LS: 10.16±0.51		
VSR5	1 to 750K	350	0.75W	0.6W (up to 300k) 0.4W 0.3W (over 300k)	W: 4.06 maximum L: 20.83 maximum H: 10.49 maximum ST: 0.89±0.13 SW: 1.27±0.13 LL: 25.4±3.18 LS: 16.51±0.51		
VSR6	0.5 to 1M	500	1W	0.8W (up to 400k) 0.5W 0.4W (over 400k)	W: 6.60 maximum L: 30.48 maximum H: 10.49 maximum ST: 0.889±0.13 SW: 1.27±0.13 LL: 25.4±3.18 LS: 22.86±0.51		

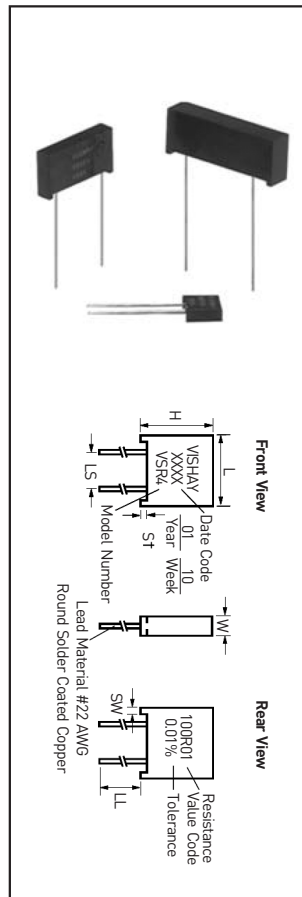

Model	Resistance Range[Ω]	Resistance Tolerance(%)	MAX. TCR [ppm/°C] <sup>(1)</sup>	Power at +25°C [W]	Maximum Voltage[V]
	25 to < 50	[±0.02]	±7		
	10 to < 25	[±0.05]	±10		
	5 to < 10	[±0.1]	±13		
	2 to < 5	[±0.25]	±20		
	1 to < 2	[±0.5]	±25		
	0.5 < 1	[±1.0]	±50		
	0.25 to < 0.5	[±2.0]			
	0.1 to < 0.25	[±5.0]			
VHP-4	10 to 500	[±0.01]		±5	
	5 to < 10	[±0.02]	±6		
	2 to < 5	[±0.05]	±8		
	1 to < 2	[±0.1]	±10		
	0.5 to < 1	[±0.25]	±15		
	0.25 to < 0.5	[±0.5]	±20		
	0.1 to < 0.25	[±1.0]	±25		
	0.05 to < 0.1	[±2.0]	±30		

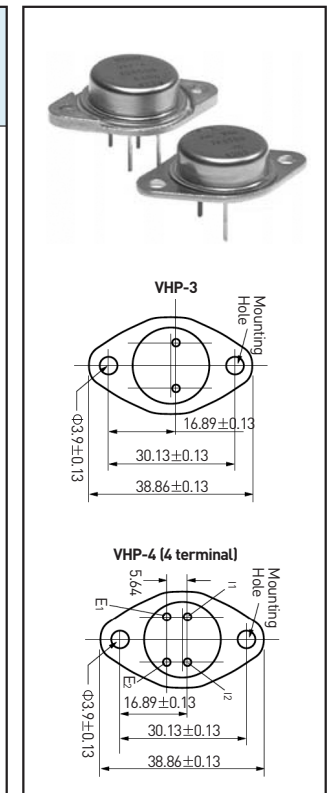

(1) -55°C to +125°C +25°C ref

Model	Resistance Range[Ω]	Maximum Working Voltage[V]	Power		Tolerance [%]	TCR Range <sup>2,3</sup>
			at +70°C	at +125°C		
VTA56	5 to 24R9 25 to 150K	300	0.25W	0.125W	[±0.1] [±0.01]	V4 Standard V3, V2 (Available)
VTA55	5 to 24R9 25 to 150K	300	0.3W	0.15W	[±0.1] [±0.01]	V4 Standard V3, V2 (Available)
VTA54	5 to 24R9 25 to 300K	300	0.5W	0.25W	[±0.1] [±0.01]	V4 Standard V3, V2 (Available)
VTA53	5 to 24R9 25 to 300K	300	0.66W	0.33W	[±0.1] [±0.01]	V4 Standard V3, V2 (Available)
VTA52	5 to 24R9 25 to 500K	300	1.0W	0.5W	[±0.1] [±0.01]	V4 Standard V3, V2 (Available)
VMTA55	5 to 49R9 50 to 30K	200	0.2W	0.1W	[±0.1] [±0.01]	V4 Standard V3, V2 (Available)
VMTB60	5 to 49R9 50 to 60K	250	0.25W	0.125W	[±0.1] [±0.01]	V4 Standard V3, V2 (Available)

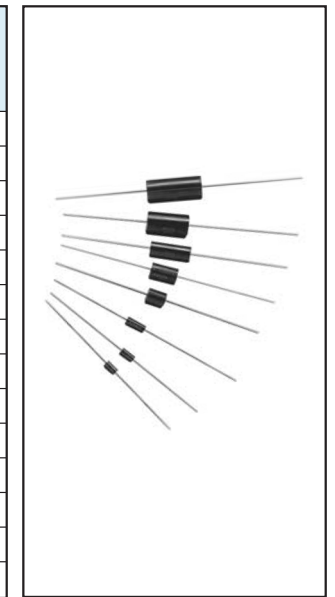

Notes:

- For higher/lower resistance values, consult the Application Engineering Department.
- TCR options for values > 50 ohms (Reference + 25°C)  
 V4 = 4ppm/°C (0 to +60°C); 8ppm/°C (-55°C to +125°C)  
 V3 = 3ppm/°C (0 to +60°C); 5ppm/°C (-55°C to +125°C)  
 V2 = 2ppm/°C (0 to +60°C); 5ppm/°C (-55°C to +125°C)

3. V4 TCR for values 50Ω

VALUES	TCR(for values under 50R) - TCR (ppm/°C)	
	0°C to +60°C	-55 to +125°C +25°C Ref.
25R - 50R	5	8
15R - 24R999	6	10
5R - 14R999	8	12
1R - 4R999	15	20

## SMD Resistor Net works

- NiCr thin film resistor networks exhibiting 2ppm/°C tracking and a 0.2% ratio.
  - A 50mW/resistor rating is sufficiently derated power for 5V analog circuits.
  - The 8-pin design affords flexibility in circuit design.
  - Supplied in plastic reel for automated assembly.
  - Custom-designed 8-pin configurations available.
- Application include: measurement, industrial electronics and instruments, automatic testing, high speed digital data transmission, intelligent hubs and routers, data switching.

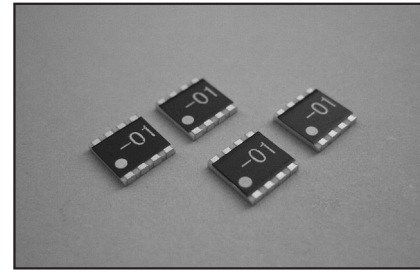

### GENERAL SPECIFICATIONS

Model	Resistance Range[Ω]	TCR		Tolerance(%)		Rating Power		Operating Temp range
		Absolute	Tracking	Absolute	Matching	Resistor	Package	
MCM8	100Ω ~ 22KΩ	±5ppm/°C	±2ppm/°C	B [±0.1]	Q [±0.02]	50mW	0.2W	-55°C ~ +120°C

### CHARACTERISTICS

Short Time Overload	[±0.05%] absolute	Rated power × 2.5, 5secs.
Insulation Resistance	> 10,000MΩ	
Dielectric Withstanding Voltage	[±0.05%] absolute	100V for 60secs.
Heat Shock	[±0.1%] absolute	5 cycles for temp. -65°C, +25°C, +125°C, +25°C
Soldering Heat	[±0.05%] absolute	350°C, 3secs.
Solderability	Covered 95% area	230°C, 3secs.
Solvent	No mechanical damage	
Humidity	[±0.1%] absolute	40°C, 90-95% RH, DC 0.1W, 1000hours
Load Life	[±0.1%]	70°C, 90minutes on, 30minutes off, 1000hours

### DIMENSIONS [mm]

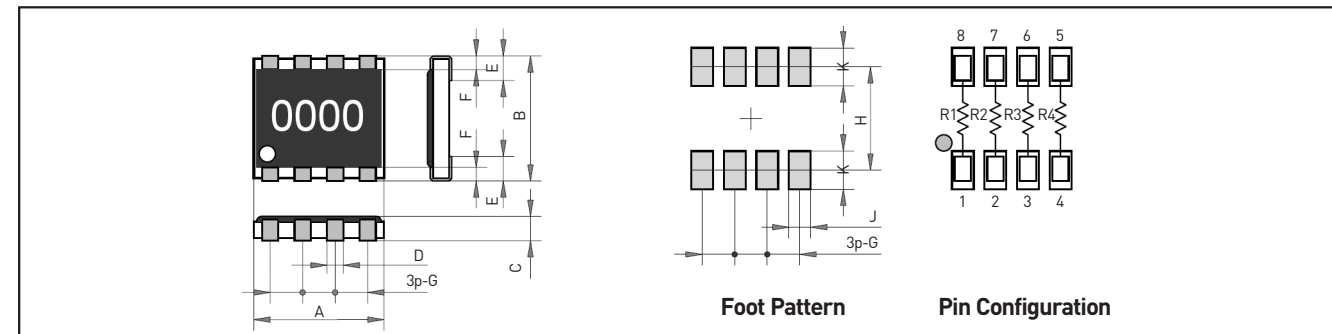

A	B	C	D	E	F	G	H	J	K
5.00±0.2	5.00±0.1	0.80±0.2	0.635±0.1	1.00±0.2	(0.5)	1.27±0.1	4.00	0.635±0.1	1.00

### DERATING CURVES

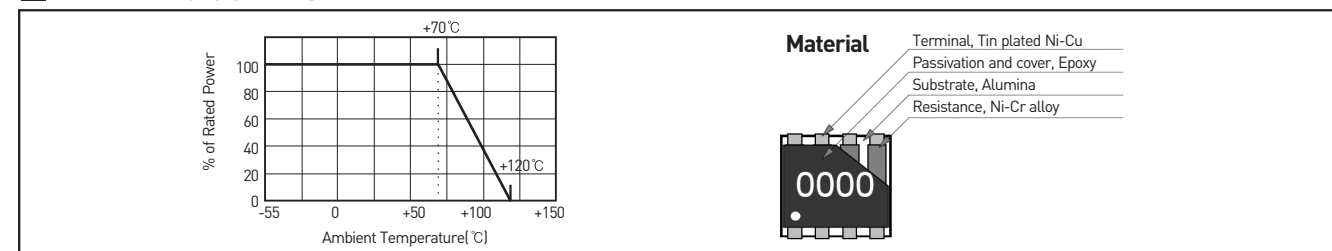

### ORDERING PROCEDURE EXAMPLE

